

# CMOS 2.4GHZ ZIGBEE/ISM TRANSMIT/RECEIVE RFeIC

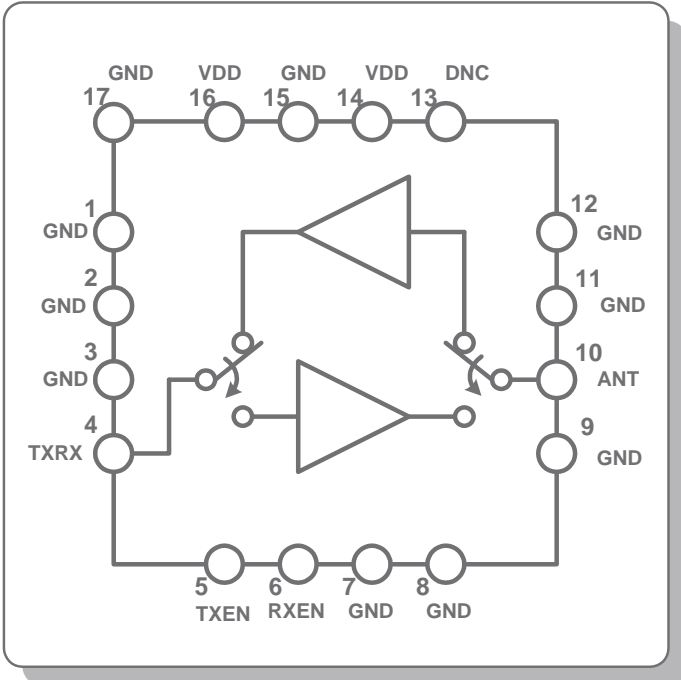

## Description

The RFX2401C is a fully integrated, single-chip, single-die RFeIC (RF Front-end Integrated Circuit) which incorporates all the RF functionality needed for IEEE 802.15.4/ZigBee, wireless sensor network, and any other wireless systems in the 2.4GHz ISM band. The RFX2401C architecture integrates the PA, LNA, Transmit and Receive switching circuitry, the associated matching network, and the harmonic filter all in a CMOS single-chip device.

Typical high power applications include home and industrial automation, smart power, and RF4CE among others. Combining superior performance, high sensitivity and efficiency, low noise, small form factor, and low cost, RFX2401C is the perfect solution for applications requiring extended range and bandwidth. RFX2401C has simple and low-voltage CMOS control logic, and requires minimal external components for system implementation.

## Applications

- ▶ ZigBee Extended Range Devices
- ▶ ZigBee Smart Power
- ▶ Wireless Sound and Audio Systems
- ▶ Home and Industrial Automation
- ▶ Wireless Sensor Networks
- ▶ Custom 2.4GHz Radio Systems

## FEATURES

- ▶ 2.4GHz ZigBee High Power Single-Chip, Single-Die RF Front-End IC
- ▶ Combined TX / RX Transceiver Port and Single Antenna Port
- ▶ 2.4GHz Transmit High Power Amplifier with Low-Pass Harmonic Filter
- ▶ Low Noise Amplifier
- ▶ Transmit / Receive Switch Circuitry
- ▶ High Transmit Signal Linearity Meeting Standards for OQPSK Modulation
- ▶ Integrated Power Detector for Transmit Power Monitor and Control
- ▶ Low Voltage (1.2V) CMOS Control Logic
- ▶ ESD Protection Circuitry on All Ports
- ▶ DC Decoupled RF Ports
- ▶ Internal RF Decoupling on All VDD Bias Pins
- ▶ Low Noise Figure for the Receive Channel
- ▶ Very Low DC Power Consumption
- ▶ Full On-chip Matching and Decoupling Circuitry
- ▶ Minimal External Components Required
- ▶ 50-Ohm Input / Output Matching
- ▶ Market Proven CMOS Technology
- ▶ 3 x 3 x 0.55mm Small Outline QFN-16 Package with Exposed Ground Pad

RFeIC® is a registered trademark of RFaxis, Inc. All rights reserved.

This product document is a general list of parameters to provide information on the capabilities of this device and is subject to change without notice.

1

### PIN ASSIGNMENTS:

Pin Number	Pin Name	Description
4	TXRX	RF signal to / from the Transceiver: DC shorted to GND
5	TXEN	CMOS Input to Control TX Enable
6	RXEN	CMOS Input to Control RX Enable
10	ANT	RF Signal from the PA or RF Signal Applied to the LNA; DC Shorted to GND
1, 2, 3, 7, 8, 9, 11, 12, 15, 17	GND	Ground – Must be connected to Ground in the Application Circuit
13	DNC	Reserved – Do Not Connect in the Application Circuit
14	VDD	Alternative Voltage Supply Pin, internally connected to Pin 16, no connection needed
16	VDD	Voltage Supply Connection

### PIN-OUT DIAGRAM:

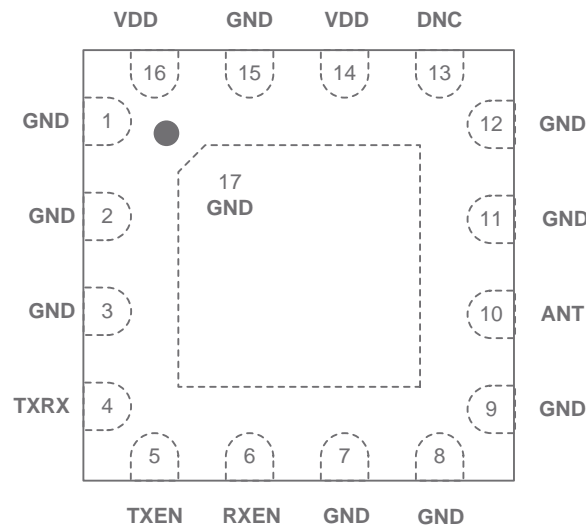

(Top View)

RFIC® is a registered trademark of RFaxis, Inc. All rights reserved.

This product document is a general list of parameters to provide information on the capabilities of this device and is subject to change without notice.

**ABSOLUTE MAXIMUM RATINGS:**

Parameters	Units	Min	Max	Conditions
DC VDD Voltage Supply	V	0	4.0	
DC Control Pin Voltage	V	0	3.6	Through 1Kohm resistor
DC VDD Current Consumption	mA		350	Through VDD Pins when TX is "ON"
DC Control Pin Current Consumption	μA		1	
TX RF Input Power	dBm		+5	All Operating Modes
ANT RF Input Power	dBm		+5	When RX is "ON"
Storage Ambient Temperature	°C	-50	+125	No RF and DC Voltages Applied Appropriate care required according to JEDEC Standards

*Note: Sustained operation at or above the Absolute Maximum Ratings for any one or combinations of the above parameters may result in permanent damage to the device and is not recommended. All Maximum RF Input Power Ratings assume 50-Ohm terminal impedance.*

**RECOMENDED OPERATING CONDITIONS:**

Parameters	Units	Min	Typ	Max	Conditions
DC VDD Voltage Supply	V	2.0	3.3	3.6	All VDD Pins
Control Voltage "High"	V	1.2		VDD	Through 1Kohm resistor
Control Voltage "Low"	V	0		0.3	
Operating Ambient Temperature	°C	-40		+85	

TRANSMIT TECHNICAL PARAMETERS (VDD=3.3V; T=+25 °C)

Parameters	Units	Min	Typ	Max	Conditions
Operating Frequency Band	GHz	2.4		2.525	All RF Pins Terminated by 50 Ohm
Saturated Output Power	dBm		+22		
Small-Signal Gain	dB		25		
Second Harmonic	dBm/MHz		-15		P <sub>OUT</sub> = +20dBm, IEEE 802.15.4 OQPSK modulation signal
Third Harmonic	dBm/MHz		-20		P <sub>OUT</sub> = +20dBm, IEEE 802.15.4 OQPSK modulation signal
Input Return Loss	dB		-10		
Output Return Loss	dB		-8		
Input / Output Impedance Single-Ended	Ohm		50		
TX Quiescent Current	mA		17		No RF Applied
TX High Power Current	mA		100		P <sub>OUT</sub> = +20dBm
Load VSWR for Stability (Pout=+20dBm)	N/A		6:1		All Non-Harmonically Related Spurs Less than -43dBm/MHz
Load VSWR for Ruggedness (Pout=+20dBm)	N/A		10:1		No Damage

RECEIVE TECHNICAL PARAMETERS (VDD=3.3V; T=+25 °C)

Parameters	Units	Min	Typ	Max	Conditions
Operating Frequency Band	GHz	2.4		2.525	All RF Pins Terminated by 50 Ohm
Gain	dB		12		
Noise Figure	dB		2.5		
Input Return Loss	dB		-12		
Output Return Loss	dB		-15		
RF Port Impedance	Ohm		50		
RX Quiescent Current	mA		10		No RF Applied
Input P <sub>1dB</sub>	dBm		-8		At ANT Pin

RFelC® is a registered trademark of RFaxis, Inc. All rights reserved.

This product document is a general list of parameters to provide information on the capabilities of this device and is subject to change without notice.

STANDBY MODE TECHNICAL PARAMTERS:

Parameters	Units	Min	Typ	Max	Conditions
DC Shutdown Current	μA			1	
TXRX-ANT Insertion Loss (S21)	dB		-50		Pin < -20dBm
ANT-TXRX Insertion Loss (S21)	dB		-50		
Return Loss (S11)	dB		-1.5		From TXRX Port
Transmit-Receive Switching Time	nsec		800		
Shut-Down and "ON" State Switching Time	nsec		800		

CONTROL LOGIC TRUTH TABLE

TXEN	RXEN	Operating Conditions
1	X	TX Active
0	1	RX Active
0	0	Chip is Shut-down

Note: "1" denotes high voltage state (> 1.2V)  
 "0" denotes low voltage stage (<0.3V) at Control Pins  
 "X" denotes do not care: either "1" or "0" can be applied

APPLICATION CIRCUIT GUIDELINES

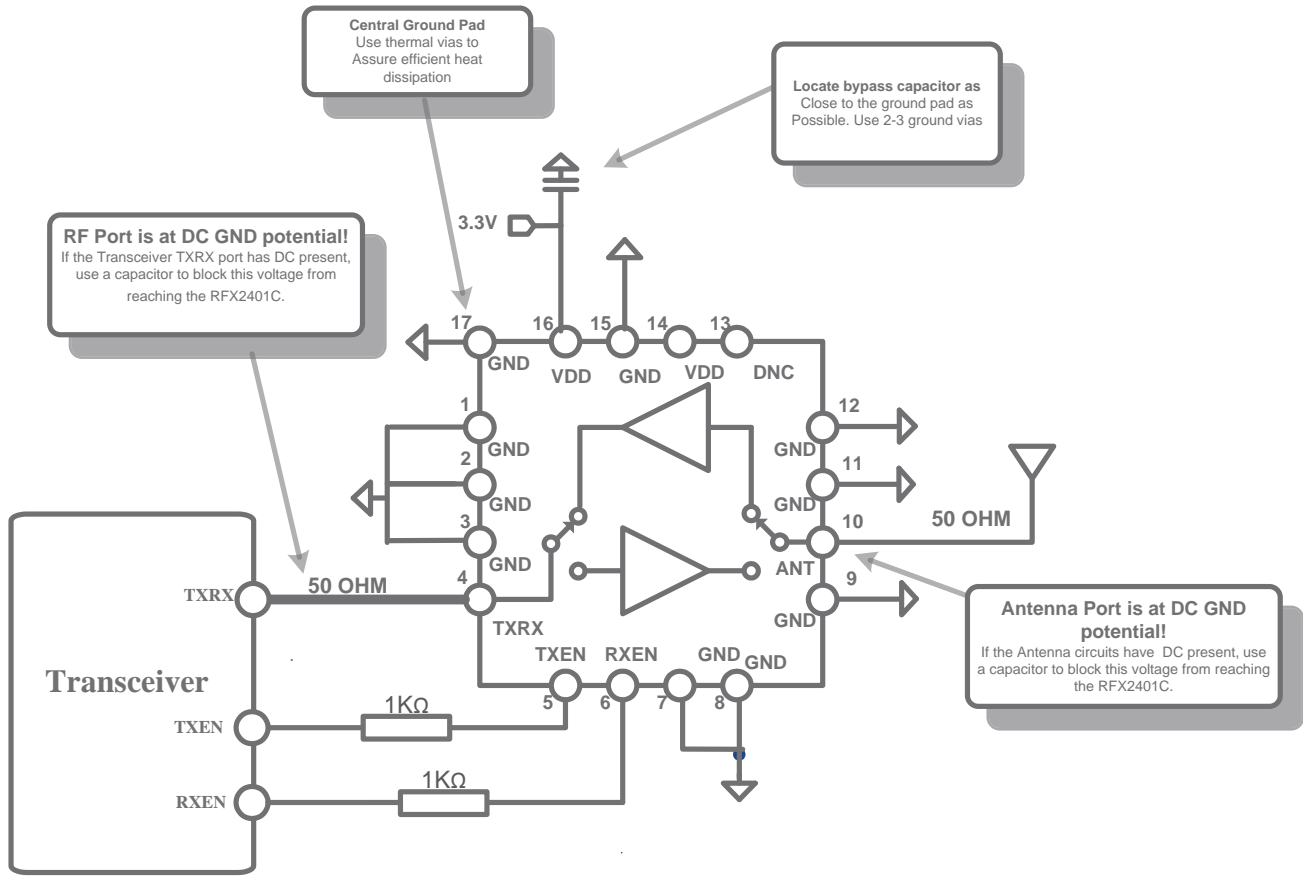

PCB LAND PATTERN

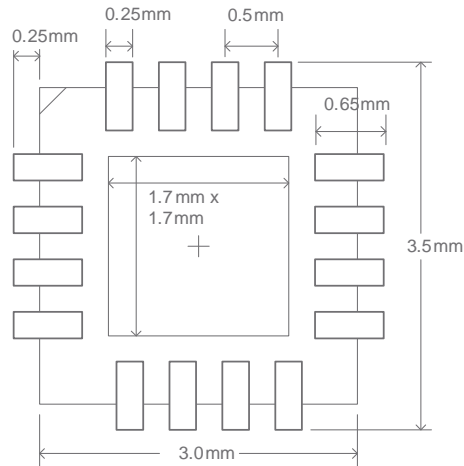

RFIC® is a registered trademark of RFaxis, Inc. All rights reserved.

This product document is a general list of parameters to provide information on the capabilities of this device and is subject to change without notice.

PACKAGE DIMENSIONS:

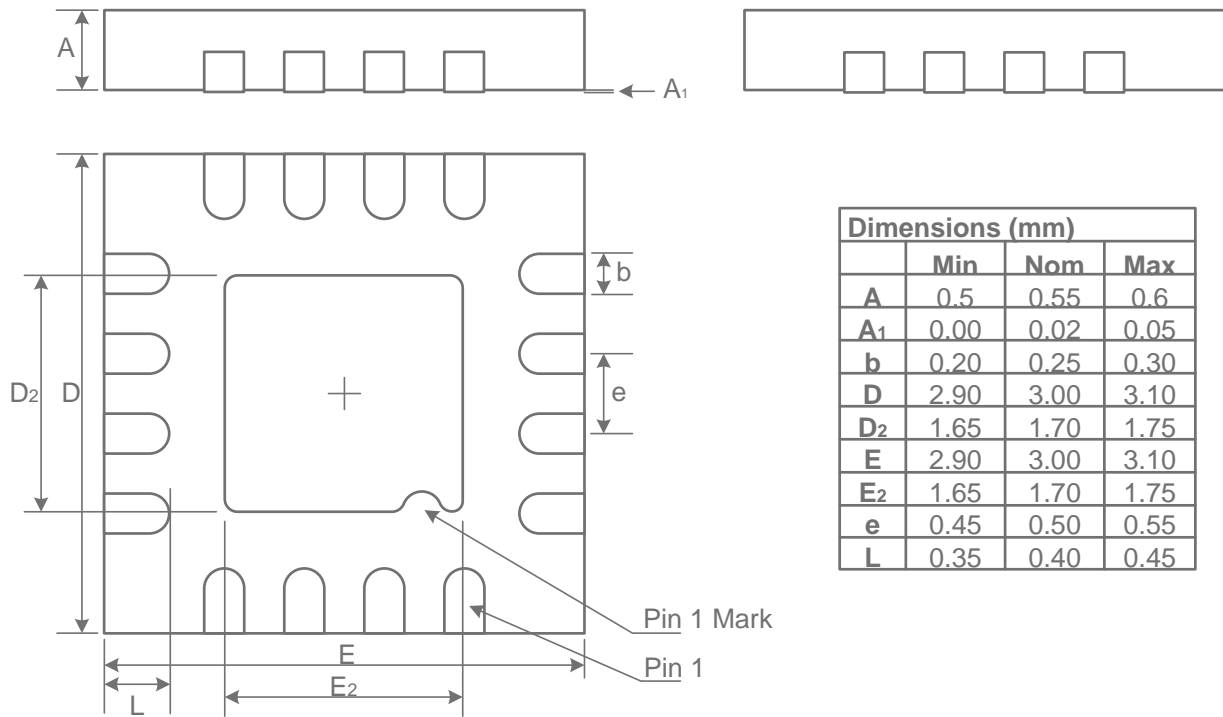

PACKAGE MARKING:

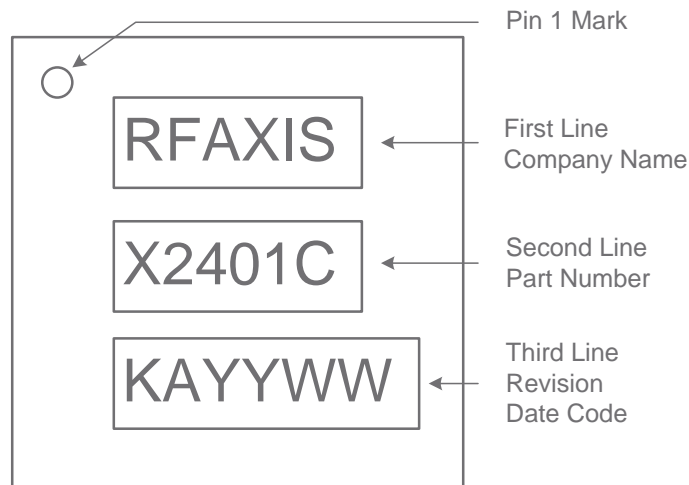

RFelC® is a registered trademark of RFaxis, Inc. All rights reserved.

This product document is a general list of parameters to provide information on the capabilities of this device and is subject to change without notice.

TAPE AND REEL INFORMATION:

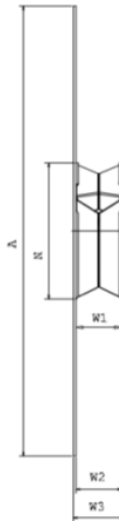
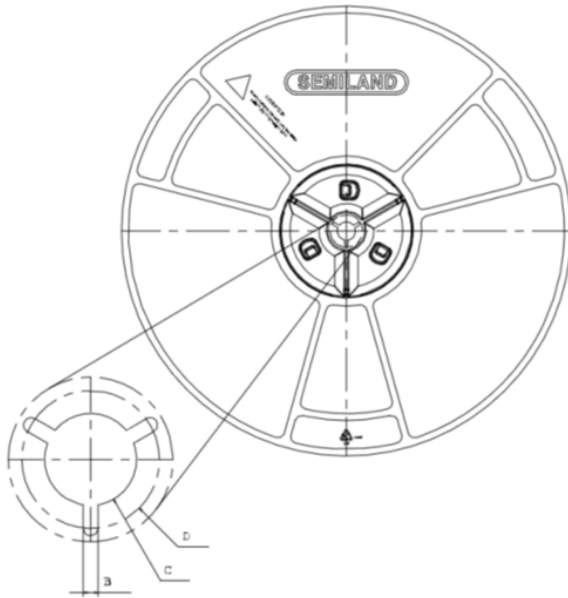
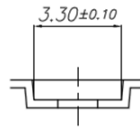
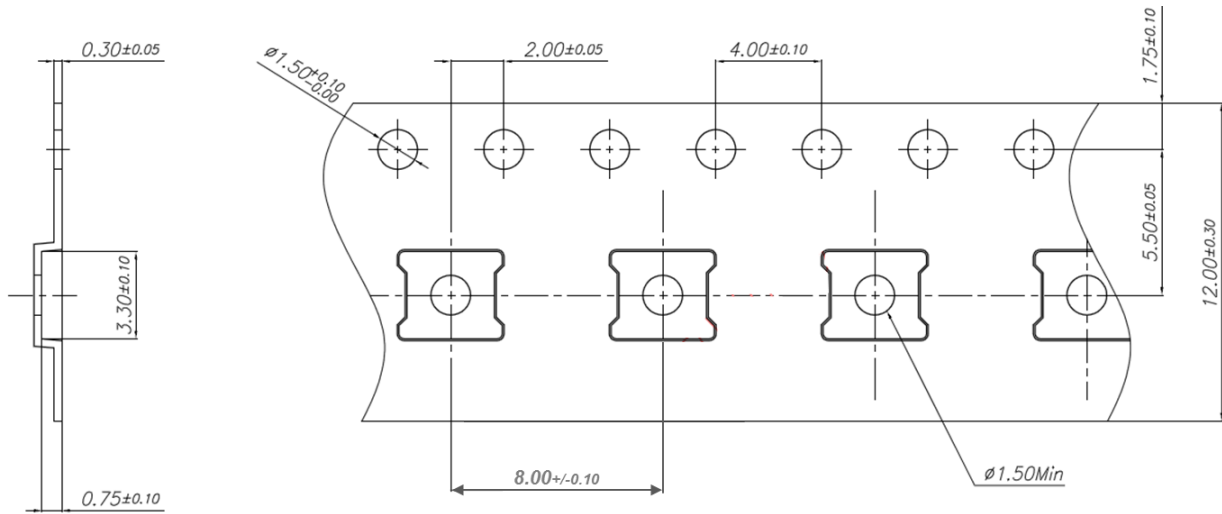

Size	12mm
A	330 <sup>+0.2</sup> <sub>-2.0</sub>
B	1.5min
C	13.0 <sup>+0.5</sup> <sub>-0.2</sub>
D	20.2min
N	100 <sup>+2.0</sup> <sub>-0.0</sub>
W1	12.4 <sup>+3.0</sup> <sub>-0.0</sub>
W2	12.4 <sup>+3.0</sup> <sub>-0.0</sub>
W3	16.4 <sup>+2.0</sup> <sub>-2.0</sub>
PART#	SRL-12134H

RFIC® is a registered trademark of RFaxis, Inc. All rights reserved.

This product document is a general list of parameters to provide information on the capabilities of this device and is subject to change without notice.



### RECOMMENDED SOLDER REFLOW PROFILE:

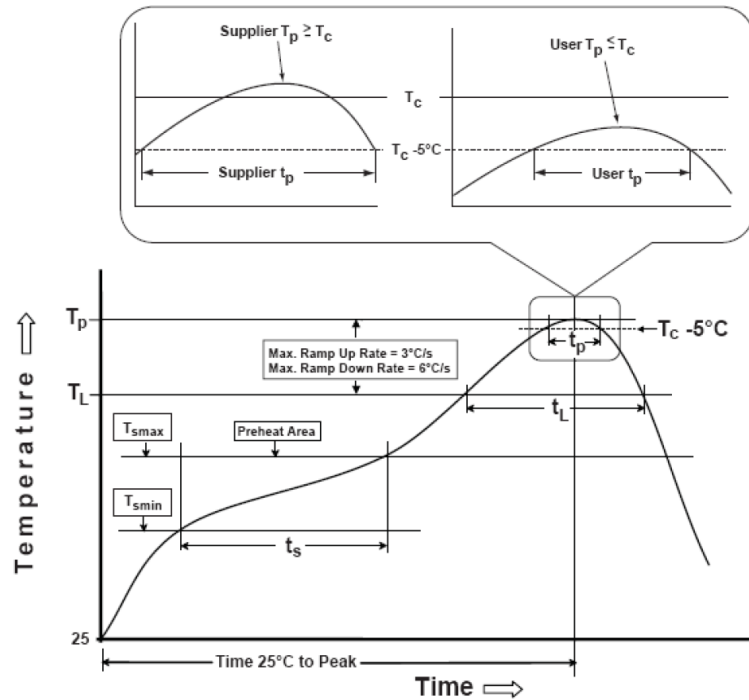

Profile Feature	Sn-Pb Eutectic Assembly	Pb-Free Assembly
<b>Preheat/Soak</b>		
Temperature Min ( $T_{smin}$ )	100 °C	150 °C
Temperature Max ( $T_{smax}$ )	150 °C	200 °C
Time ( $t_s$ ) from ( $T_{smin}$ to $T_{smax}$ )	60-120 seconds	60-120 seconds
Ramp-up rate ( $T_L$ to $T_p$ )	3 °C/second max.	3 °C/second max.
Liquidous temperature ( $T_L$ )	183 °C	217 °C
Time ( $t_L$ ) maintained above $T_L$	60-150 seconds	60-150 seconds
Peak package body temperature ( $T_p$ )	For users $T_p$ must not exceed the Classification temp in Table 4-1. For suppliers $T_p$ must equal or exceed the Classification temp in Table 4-1.	For users $T_p$ must not exceed the Classification temp in Table 4-2. For suppliers $T_p$ must equal or exceed the Classification temp in Table 4-2.
Time ( $t_p$ )* within 5 °C of the specified classification temperature ( $T_c$ ), see Figure 5-1.	20* seconds	30* seconds
Ramp-down rate ( $T_p$ to $T_L$ )	6 °C/second max.	6 °C/second max.
Time 25 °C to peak temperature	6 minutes max.	8 minutes max.

\* Tolerance for peak profile temperature ( $T_p$ ) is defined as a supplier minimum and a user maximum.

#### SnPb Eutectic Process - Classification Temperatures ( $T_c$ )

Package Thickness	Volume mm <sup>3</sup> <350	Volume mm <sup>3</sup> ≥350
<2.5 mm	235 °C	220 °C
≥2.5 mm	220 °C	220 °C

#### Pb-Free Process - Classification Temperatures ( $T_c$ )

Package Thickness	Volume mm <sup>3</sup> <350	Volume mm <sup>3</sup> 350 - 2000	Volume mm <sup>3</sup> >2000
<1.6 mm	260 °C	260 °C	260 °C
1.6 mm - 2.5 mm	260 °C	250 °C	245 °C
>2.5 mm	250 °C	245 °C	245 °C

RFelC® is a registered trademark of RFaxis, Inc. All rights reserved.

This product document is a general list of parameters to provide information on the capabilities of this device and is subject to change without notice.